

**100 Series:
Best value for money!**

**Up to 30%
More competitive!**

103



AMCO / VEBA
LIFTING BEYOND HORIZONS

Technical data

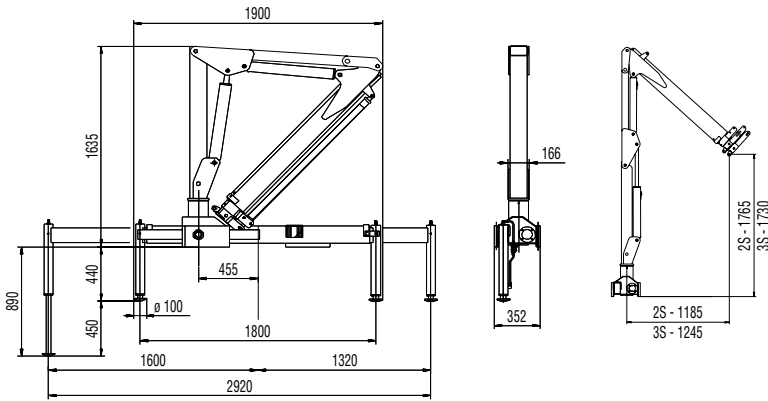

2S		2S					
kg	m	2600	1300	850	585	445	330
		1,00*	2,00*	3,06	4,26	5,45	6,75

3S		3S					
kg	m	2520	1260	800	545	410	330
		1,00*	2,00*	3,15	4,35	5,55	6,75

*) theoretical lifting capacity

Standard

- Designed in accordance with EN12999+EN13849
- Design class: HC1-HD4
- Dual-side controls
- Hexagonal booms
- Sliding pads on telescopic extensions
- Self-lubricating bushings
- DIN and JIC fittings
- Assembly kit included
- Mechanical rotation limitation (CE)
- Light indicator for correct stabilizer stowing (CE)
- Oil tank

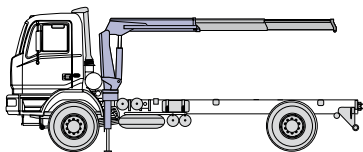

Recommended truck:
M.T.T. ton 3,5 - G.V.W. ton 3,5

	Lifting Moment	Slewing Angle	Working pressure	Oil tank capacity	Oil flow	Max Vertical Reach (Hydr)	Crane weight without stabilizers
	tm	°	bar	l	l/min	m	kg
2S	2,60	370	205	17,5	10	7,93	435
3S	2,52	370	205	17,5	10	9,19	465



H.C.E. SpA
Via Einstein, 4
42028 Poggio (RE) Italy
Tel. +39 0522 40.80.11
Fax +39 0522 40.80.80
info@amcoveba.it
commerciale@amcoveba.it
www.amcoveba.com



Dealer

Data, descriptions, and illustrations pertain only and uniquely to models sold at the time of printing of this brochure. After the date of printing, this information is purely indicative and not binding upon H.C.E. Future modifications are solely at the discretion of H.C.E. and are always in compliance with applicable and pertinent safety standards. To obtain updated data, descriptions, and illustrations, contact the manufacturer or your reseller. Cranes manufactured and/or marketed by H.C.E. are not responsible for the special applications depicted. Crane applications and accessories described herein are only examples. Some applications and equipment shown may not be approved for use in CE countries or other areas. It is the installer's responsibility to ensure that the crane is applied correctly, and that its application, installation, and accessories maintain safety and comply with all local laws.