

New Generation
909NG
C



AMCO  **VEBA**
LIFTING BEYOND HORIZONS

New Generation

Technical data 909NG C

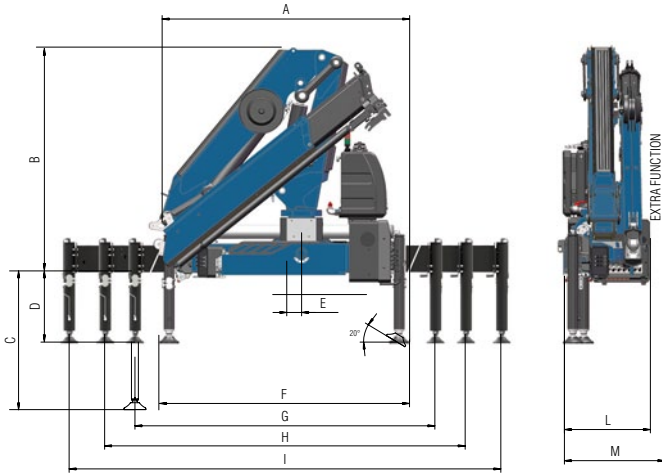

	2S	3S
A	2285	2285
B	2085	2085
C	1185	1185
D	585	585
E	160	160
F	2270	2270
G	3290	3290
H	4790	4790
I	5755	5755
L	840	840
M	885	885
N	2290	2210

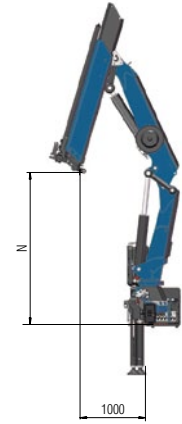

	2S				3S				
kg	8290	2390	1700	1210	8040	2265	1555	1115	850
m	1,00*	3,47	4,91	6,72	1,00*	3,55	5,00	6,80	8,75

*) theoretical lifting capacity

Standard

- Designed in accordance with EN12999:2020 + EN13849
- Design class: HC1-HD4
- Cross controls
- Flanged valves
- Oil tank
- Manually extendable stabilizers
- Fixed stabilizer cylinders
- Swivel stabilizer foot
- Centralized greasing system
- Double linkage
- SGS Sprint Generation System
- SDD Soft Descent Drive
- A Class - Crane Control System (CE)
- LED panel - Human Machine Interface

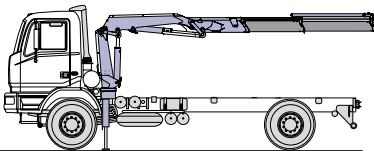

Recommended truck:
M.T.T. ton 8 - G.V.W. ton 8

	Lifting Moment	Swinging Angle	Working pressure	Oil tank capacity	Oil flow	Max Vertical Reach (Hydr)	Crane weight without stabilizers
	tm	°	bar	l	l/min	m	kg
2S	8,3	425	315	75	40	10,1	1170
3S	-	425	315	75	40	12,2	1260

AMCO VEBA
LIFTING BEYOND HORIZONS

H.C.E. SpA
Via Einstein, 4
42028 Poggio (RE) Italy
Tel. +39 0522 40.80.11
Fax +39 0522 40.80.80
info@amcoveba.it
commerciale@amcoveba.it
www.amcoveba.com



Dealer